



Transportation
Safety Board
of Canada

Bureau de la sécurité
des transports
du Canada

AIR TRANSPORTATION SAFETY INVESTIGATION REPORT A23W0096

LOSS OF CONTROL AND COLLISION WITH WATER

Cooking Lake Aviation Academy Inc.
Diamond Aircraft Industries Inc. DA20-C1, C-FRZG
Cooking Lake Aerodrome (CEZ3), Alberta, 20 NM E
11 August 2023

ABOUT THIS INVESTIGATION REPORT

This report is the result of an investigation into a class 3 occurrence. For more information, see the Policy on Occurrence Classification at www.tsb.gc.ca

The Transportation Safety Board of Canada (TSB) investigated this occurrence for the purpose of advancing transportation safety. It is not the function of the Board to assign fault or determine civil or criminal liability.

TERMS OF USE

Use in legal, disciplinary or other proceedings

The *Canadian Transportation Accident Investigation and Safety Board Act* states the following:

- 7(3) No finding of the Board shall be construed as assigning fault or determining civil or criminal liability.
- 7(4) The findings of the Board are not binding on the parties to any legal, disciplinary or other proceedings.

Therefore, the TSB's investigations and the resulting reports are not created for use in the context of legal, disciplinary or other proceedings.

Notify the TSB in writing if this investigation report is being used or might be used in such proceedings.

Non-commercial reproduction

Unless otherwise specified, you may reproduce this investigation report in whole or in part for non-commercial purposes, and in any format, without charge or further permission, provided you do the following:

- Exercise due diligence in ensuring the accuracy of the materials reproduced.
- Indicate the complete title of the materials reproduced and name the Transportation Safety Board of Canada as the author.
- Indicate that the reproduction is a copy of the version available at [URL where original document is available].

Commercial reproduction

Unless otherwise specified, you may not reproduce this investigation report, in whole or in part, for the purposes of commercial redistribution without prior written permission from the TSB.

Materials under the copyright of another party

Some of the content in this investigation report (notably images on which a source other than the TSB is named) is subject to the copyright of another party and is protected under the *Copyright Act* and international agreements. For information concerning copyright ownership and restrictions, please contact the TSB.

Citation

Transportation Safety Board of Canada, *Air Transportation Safety Investigation Report A23W0096* (released 29 January 2025).

Transportation Safety Board of Canada
200 Promenade du Portage, 4th floor
Gatineau QC K1A 1K8
819-994-3741; 1-800-387-3557
www.tsb.gc.ca
communications@tsb.gc.ca

© His Majesty the King in Right of Canada, as represented by the Transportation Safety Board of Canada, 2025

Air transportation safety investigation report A23W0096

Cat. No. TU3-10/23-0096E-1-PDF
ISBN: 978-0-660-75162-7

This report is available on the website of the Transportation Safety Board of Canada at www.tsb.gc.ca

Le présent rapport est également disponible en français.

Table of contents

1.0	Factual information	6
1.1	History of the flight.....	6
1.2	Injuries to persons.....	8
1.3	Damage to aircraft.....	8
1.4	Other damage.....	8
1.5	Personnel information.....	8
1.5.1	Flight instructor.....	9
1.5.2	Student pilot	9
1.6	Aircraft information	9
1.7	Meteorological information	11
1.8	Aids to navigation	11
1.9	Communications.....	11
1.9.1	Cooking Lake Aviation Academy Inc.'s overdue / missing aircraft procedures	11
1.10	Aerodrome information.....	12
1.11	Flight recorders	12
1.12	Wreckage and impact information.....	12
1.13	Medical and pathological information.....	13
1.14	Fire.....	13
1.15	Survival aspects	13
1.15.1	ARTEX ELT 1000 emergency locator transmitter	13
1.15.2	Flight itinerary and flight plan.....	18
1.16	Tests and research	19
1.17	Organizational and management information.....	19
1.17.1	Cooking Lake Aviation Academy Inc.....	19
1.18	Additional information.....	19
1.18.1	Aerodynamic stall and incipient spin	19
1.18.2	Spin certification of the Diamond DA20-C1.....	20
1.18.3	Diamond DA20-C1 spin recovery procedure.....	21
1.18.4	Spin recovery altitude.....	21
1.18.5	Spin training	22
1.18.6	Instructional method	23
2.0	Analysis	25
2.1	Spin	25
2.2	Emergency locator transmitter.....	26
3.0	Findings.....	27
3.1	Findings as to causes and contributing factors.....	27
3.2	Findings as to risk.....	27

4.0	Safety action.....	28
4.1	Safety action taken	28
4.1.1	Diamond Aircraft Industries Inc.....	28
4.1.2	Cooking Lake Aviation Academy Inc.....	28
4.1.3	Transport Canada.....	28

AIR TRANSPORTATION SAFETY INVESTIGATION REPORT A23W0096

LOSS OF CONTROL AND COLLISION WITH WATER

Cooking Lake Aviation Academy Inc.
Diamond Aircraft Industries Inc. DA20-C1, C-FRZG
Cooking Lake Aerodrome (CEZ3), Alberta, 20 NM E
11 August 2023

The Transportation Safety Board of Canada (TSB) investigated this occurrence for the purpose of advancing transportation safety. It is not the function of the Board to assign fault or determine civil or criminal liability. **This report is not created for use in the context of legal, disciplinary or other proceedings.** See the Terms of use on page 2.

Summary

On 11 August 2023, a Cooking Lake Aviation Academy Inc. Diamond Aircraft Industries Inc. DA20-C1 aircraft (registration C-FRZG; serial number C0746) was conducting a flight from the Cooking Lake Aerodrome, Alberta. It was a training flight for a private pilot licence, with a flight instructor and student pilot on board.

While in the local training area, the aircraft collided with the surface of Beaverhill Lake, 20 nautical miles east of the Cooking Lake Aerodrome at 1806:43 Mountain Daylight Time (MDT). The aircraft came to rest in shallow water. There was no post-impact fire.

The 406 MHz emergency locator transmitter did not automatically activate upon impact.

Cooking Lake Aviation Academy Inc. activated its emergency response plan at 2000 MDT in response to the overdue flight and the Joint Rescue Coordination Centre in Trenton, Ontario, initiated search activities at 2100 MDT. The aircraft was found shortly after midnight MDT on 12 August 2023.

When first responders arrived at the accident site, the flight instructor was found dead and the student pilot was found seriously injured. The student pilot was transported to an Edmonton hospital and died 2 days later as a result of his injuries.

1.0 FACTUAL INFORMATION

1.1 History of the flight

At 1732¹ on 11 August 2023, a Diamond Aircraft Industries Inc. (Diamond) DA20-C1 aircraft operated by Cooking Lake Aviation Academy Inc. (CLAA) departed from the Cooking Lake Aerodrome (CEZ3), Alberta, on a training flight with a flight instructor, seated in the right seat, and student pilot, in the left seat.

It was the student pilot's 13th training flight toward obtaining a private pilot licence.

After departing from Runway 28 and clearing the circuit, the aircraft entered a right turn toward the local practice area, located in the vicinity of Beaverhill Lake (which sits at an elevation of 2194 feet above sea level [ASL]), 20 nautical miles east of CEZ3.

The purpose of that day's training was to review slow flight and stalls, and then introduce spins and spiral dives. Flight-path information (Figure 1) transmitted from the aircraft's automatic dependent surveillance - broadcast (ADS-B) system, which was later retrieved from NAV CANADA during the investigation, was consistent with spiral dive training and spin training.

Figure 1. Occurrence flight path and accident site location (Source: Google Earth, with TSB annotations)

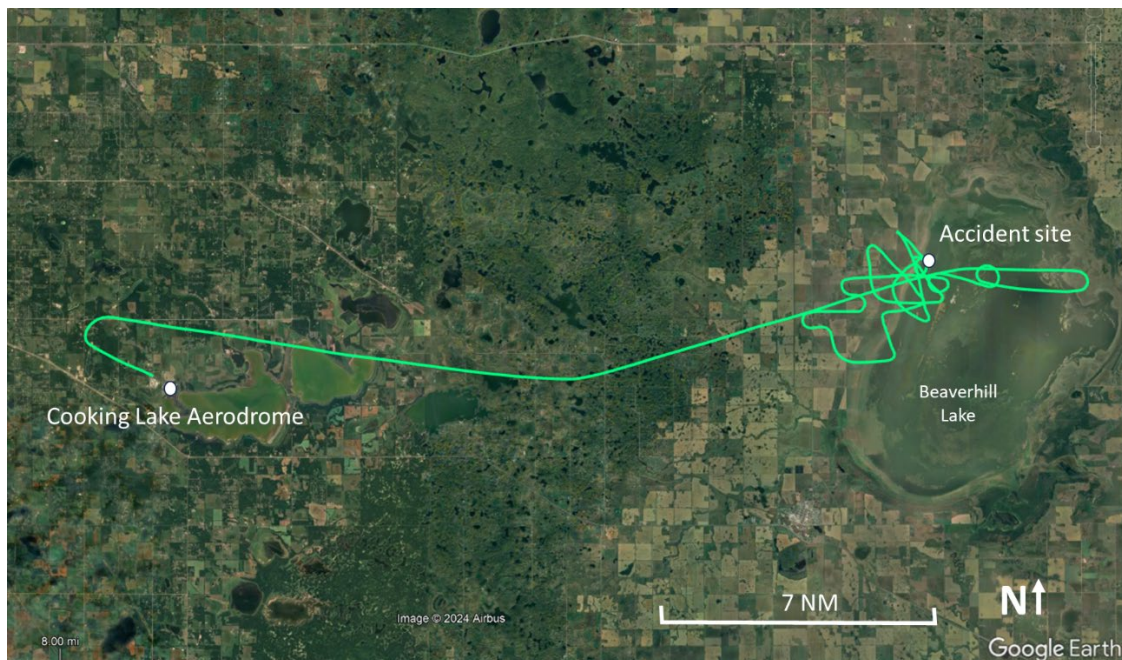

At 1744, the aircraft arrived in the practice area at an altitude of 5500 feet ASL.

For the next 21 minutes, the aircraft conducted upper-air work. At 1805:22, when the aircraft was at 5725 feet ASL, it entered the 1st of 2 spin manoeuvres. The aircraft recovered from the 1st spin at 1805:37, at an altitude of 4150 feet ASL and with a loss of

¹ All times are Mountain Daylight Time (Coordinated Universal Time minus 6 hours).

1575 feet. Over the next 36 seconds, the aircraft climbed on a track of 132° magnetic to an altitude of 4725 feet ASL.

At 1806:13, the aircraft entered the 2nd spin at 4725 feet ASL, which was 2531 feet above ground level (AGL) (Figure 2). The aircraft remained in the spin until it collided with the surface of Beaverhill Lake at 1806:43. There was no post-impact fire.

Figure 2. Graphs showing the relationship between the occurrence aircraft's altitude and ground speed during the 2 spins (Source: TSB)

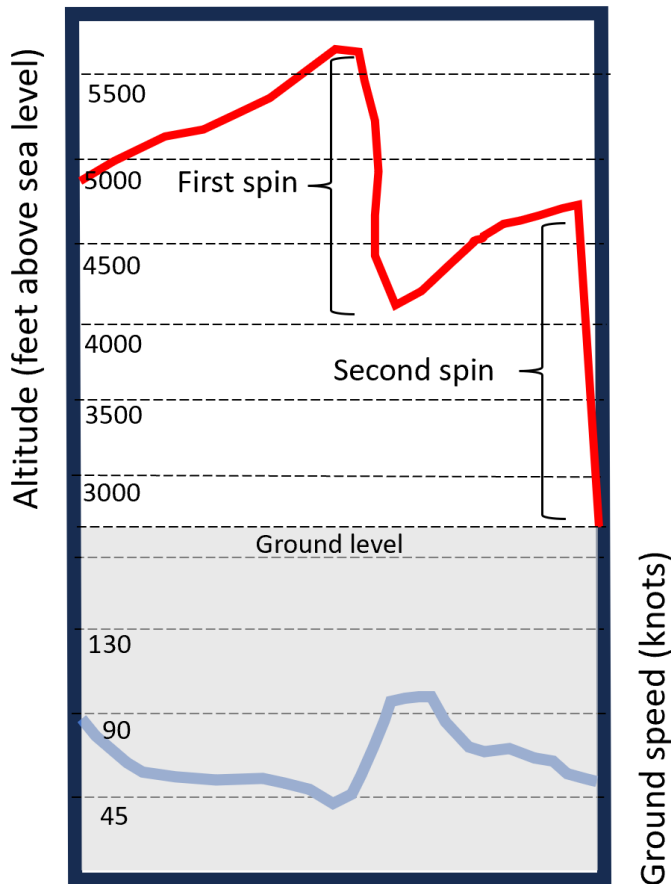

The aircraft came to rest in shallow water and the 406 MHz emergency locator transmitter (ELT) did not automatically activate upon impact.

The aircraft was declared missing at 2000 by CLAA dispatch. CLAA's emergency response plan (ERP) was activated and CLAA then initiated its own search, sending an aircraft to the practice area. At approximately 2100, the Joint Rescue Coordination Centre (JRCC) in Trenton, Ontario, was notified of the missing aircraft and then initiated search activities.

A general visual search was conducted by local first responders. However, without an ELT signal, the JRCC was unable to provide them with an accurate position, and the search participants had to assume the aircraft was in the vicinity of the Beaverhill Lake practice area, which covers approximately 140 square miles.

The sun set at 2011;² however, the search continued in the dark for a further 4 hours.

The aircraft was found shortly after midnight on 12 August 2023. When first responders arrived at the scene, the flight instructor was found dead. The student pilot was found seriously injured and transported by air ambulance to an Edmonton hospital, where he died 2 days later as a result of his injuries.

1.2 Injuries to persons

There was 1 flight instructor and 1 student pilot on board. Table 1 outlines the degree of injuries received.

Table 1. Injuries to persons

Degree of injury	Crew	Passengers	Persons not on board the aircraft	Total by injury
Fatal	2	–	–	2
Serious	0	–	–	0
Minor	0	–	–	0
Total injured	2	–	–	2

1.3 Damage to aircraft

The aircraft was destroyed by the impact forces. There was no post-impact fire.

1.4 Other damage

There was no property damage in the area surrounding the accident site, other than ground scars. Approximately 16 U.S. gallons of 100LL aviation gasoline leaked out of the fuel tank at the accident site.

1.5 Personnel information

The flight instructor held the appropriate licence and ratings for the flight in accordance with existing regulations.

Table 2. Personnel information

	Flight instructor	Student pilot
Pilot licence	Commercial pilot licence (CPL)	None
Medical expiry date	01 January 2024	01 May 2027
Total flying hours	671.1	10.9
Flight hours on type	138.5	9.3
Flight hours in the 7 days before the occurrence	5.4	3.0

² Government of Canada, National Research Council Canada, Sunrise/sunset calculator, at <https://nrc.canada.ca/en/research-development/products-services/software-applications/sun-calculator/> (last accessed on 20 August 2024).

Flight hours in the 30 days before the occurrence	25.5	3.0
Flight hours in the 90 days before the occurrence	87.8	10.0
Flight hours on type in the 90 days before the occurrence	84.6	9.3

1.5.1 Flight instructor

The flight instructor had been employed by CLAA since January 2019. He held a commercial pilot licence – aeroplane, issued on 16 September 2021, and was endorsed for single- and multi-engine landplanes. He also held a Group 1 instrument rating and a Class 4 flight instructor rating.

He had accumulated 363 hours as a flight instructor.

His last Diamond DA20-C1 evaluation flight by CLAA was on 07 March 2023.

1.5.2 Student pilot

The student pilot had started his flight training with CLAA in May 2018 with the intent of obtaining his private pilot licence. He completed 2 training flights before pausing his training until May 2023.

He held a Category 3 medical certificate that was valid until 01 May 2027 and a Restricted Operator Certificate with Aeronautical Qualification radio licence. The student pilot had not yet completed the requirements for the student pilot permit.

1.6 Aircraft information

The Diamond DA20-C1 is a low-wing, single-engine aircraft (Figure 3) primarily used for training.

Figure 3. Occurrence aircraft (Source: Cooking Lake Aviation Academy Inc.)



The fuselage is semi-monocoque and constructed primarily of glass-fibre-reinforced plastic, and the wings are of semi-monocoque sandwich construction with an I-shaped spar that has carbon-fibre-reinforced plastic caps.

The aircraft is equipped with a Continental IO-240-B engine, fixed tricycle landing gear, and a Garmin G500 TXi avionics suite, which includes automatic dependent surveillance – broadcast (ADS-B) technology. CLAA had purchased 3 new Diamond DA20-C1 aircraft, including the occurrence aircraft, the 1st of which entered into service in March 2023.

There were no recorded defects with the aircraft at the time of the occurrence. There was no indication that a component or system malfunction played a role in this occurrence.

The most recent 100-hour-interval inspection was completed on 01 August 2023. The aircraft was operating within the approved weight-and-balance envelope during the flight, with a take-off weight of 1678 pounds.

At the time of the occurrence, there were 108 Diamond DA20-C1 aircraft registered in Canada and approximately 750 DA20-C1 aircraft operating globally.

Table 3. Aircraft information

Manufacturer	Diamond Aircraft Industries Inc.
Type, model and registration	DA20-C1, C-FRZG
Year of manufacture	2023
Serial number	C0746
Certificate of airworthiness	21 February 2023
Total airframe time	348.6 hours
Engine type (number of engines)	Continental Aerospace Technologies IO-240-B (1)

Propeller type (number of propellers)	MT Propeller MT-175R-150-2CA (1)
Maximum allowable take-off weight	1764 pounds
Recommended fuel type(s)	Aviation gasoline (AVGAS) 100 or 100LL
Fuel type used	AVGAS 100LL

1.7 Meteorological information

The hourly aerodrome routine meteorological report (METAR) issued at 1800 for Edmonton International Airport (CYEG), Alberta, the closest airport to the accident site, located 31 nautical miles southeast, indicated the following:

- Winds from 260° true at 4 knots
- Visibility of 20 statute miles
- Scattered cloud layer at 13 000 feet AGL, broken ceiling at 15 000 feet AGL, and broken cloud layer at 25 000 feet AGL
- Temperature 19 °C, dew point 14 °C
- Altimeter setting 29.88 inches of mercury

Density altitude was calculated to be 3233 feet ASL, approximately 1000 feet higher than terrain elevation (2200 feet ASL) at the accident site.

Weather was not considered a factor in this occurrence.

1.8 Aids to navigation

Not applicable.

1.9 Communications

1.9.1 Cooking Lake Aviation Academy Inc.'s overdue / missing aircraft procedures

CLAA pilots communicate with CLAA dispatch on radio frequency 131.75 MHz. They use the frequency for various types of communication, including submitting local weather observations and providing flight updates. The CLAA radio is monitored by dispatch personnel on a regular basis during normal business hours. If an emergency develops, CLAA will activate its ERP. The ERP manual in place at the time of the occurrence was not a controlled document, meaning that it did not have a process by which it could be updated and have revisions recorded.

The CLAA's *Emergency Response Procedures: Overdue/Missing Aircraft*³ contains procedures for handling overdue or missing aircraft on local and cross-country flights.

³ Cooking Lake Aviation Inc., *Emergency Response Procedures: Overdue/Missing Aircraft*.

For local flights, dispatch personnel are to try to contact a potentially overdue or missing pilot via cellphone, then contact the Edmonton Flight Information Centre (FIC) to determine if any contact has been made with the aircraft and obtain the last time of contact.

For cross-country flights, dispatch personnel are to contact the Edmonton FIC to determine if any contact has been made with the aircraft and obtain the last time of contact, then call instrument flight rules (IFR) Flight Planning at the NAV CANADA Edmonton Area Control Centre.

If the aircraft is confirmed overdue or missing, dispatch personnel are to immediately contact the key personnel at CLAA, who will contact Edmonton FIC to report the aircraft missing.

The last step is to call the Royal Canadian Mounted Police (RCMP) (or other police force, if applicable) and the destination point.

1.10 **Aerodrome information**

Not applicable.

1.11 **Flight recorders**

The aircraft was not equipped with a flight data recorder or a cockpit voice recorder, nor was either required by regulation.

The aircraft was equipped with a Garmin G500 TXi avionics suite, which had the capability to record flight-path data. However, due to damage incurred during the accident, no flight-path data could be recovered from this system.

1.12 **Wreckage and impact information**

The aircraft struck the ground at an approximately 60° nose-down, left-wing-low attitude. Ground scars and the position of the wreckage indicate that the aircraft was rotating to the left. This is consistent with the aircraft being in a left spin at the time of impact.

During impact, both legs of the main landing gear collapsed directly under the wings and the nose gear collapsed under the engine cowl. The right wing remained intact (Figure 4).

The fuel tank, located in the fuselage aft of the cockpit, fractured during the accident during the breakup of the aircraft's cockpit area. Approximately 16 U.S. gallons of the fuel that remained in the tank at the time of impact leaked out at the accident site. All aircraft components were located at the accident site.

Figure 4. Accident site, looking south (Source: TSB)



The left wing had sheared from the fuselage, but the pushrods controlling the ailerons were still attached to the cabin. The tail of the aircraft broke just aft of the cabin, but the rudder control cables remained attached to the forward fuselage.

The flight-control system was verified and was noted to be continuous between those sections that had failed in overload due to impact forces. The flaps were determined to be in the up position.

When the wreckage was recovered and transported to the TSB regional office in Edmonton, Alberta, a more detailed inspection of the airframe, flight controls, and engine was completed. There were no anomalies noted.

1.13 Medical and pathological information

According to information gathered during the investigation, there was no indication that the flight instructor's or student pilot's performance was affected by medical, pathological, or physiological factors.

1.14 Fire

Not applicable.

1.15 Survival aspects

Based on conclusions from the medical examiner, this accident was not survivable.

1.15.1 ARTEX ELT 1000 emergency locator transmitter

1.15.1.1 General

The occurrence aircraft was equipped with an ACR Electronics, Inc. ARTEX ELT 1000 automatic fixed emergency locator transmitter,⁴ which, if activated automatically or manually, transmits a signal on the frequencies 121.5 MHz and 406 MHz.

⁴ Part number A3-06-2749-1, serial number 323-04392.

The ELT and mounting bracket were installed on the right aft side of the baggage compartment, which is located behind the seats and above the fuel tank (Figure 5).

The ARTEX ELT 1000 has a 3-position switch on the body of the ELT that allows for selection of Test/Reset, ARM, and ON. The ELT, which was held securely in position, was found on its mounting bracket with the

wiring harness and antenna cable attached. The ELT switch was found in the ARM position. Although the aircraft came to rest in shallow water, the ELT and its connections were not submerged.

Figure 5. The occurrence aircraft's ARTEX ELT 1000 installation, looking aft at the right side of the baggage compartment, behind the right seat (Source: TSB)



1.15.1.2 Emergency locator transmitter certification

The ELT installation in the Diamond DA20-C1 aircraft was certified by Transport Canada (TC) without a cockpit remote switch installed on the instrument panel because TC determined during the certification process that the ELT was accessible by the pilot. Therefore, no remote activation means was necessary.

Although the absence of an installed remote switch was not causal to the events of this occurrence, the investigation noted that TC's interpretation of ELT certification criteria did not consider all installation location and accessibility criteria outlined in the Radio Technical Commission for Aeronautics (RTCA) standard publication,⁵ as required by Technical Standard Order C126b,⁶ or guidance provided in Federal Aviation Administration (FAA) of the United States' Advisory Circular (AC) 91-44A,⁷ per subparagraph 551.104(f)(2) of the Canadian *Airworthiness Manual*.

⁵ Radio Technical Commission for Aeronautics Inc., RTCA DO-204B, *Minimum Operational Performance Standard for Aircraft Emergency Locator Transmitters 406 MHz* (13 December 2018).

⁶ Both the Federal Aviation Administration (FAA) of the United States and Transport Canada have published a Technical Standard Order C126b. As stipulated in the Canadian *Airworthiness Manual* subparagraph 551.104(b)(2), Canadian technical standard orders, identified as CAN-TSO, are equivalent to the corresponding FAA TSO standards.

⁷ Federal Aviation Administration (FAA), Advisory Circular (AC) 91-44A: *Installation and Inspection Procedures for Emergency Locator Transmitters and Receivers, Change 1* (01 February 2018).

1.15.1.3 Emergency locator transmitter operation

In normal operation, the ARTEX ELT 1000 is ready to activate when the switch on the ELT is set in the ARM position. A connection jumper (also called the G-switch loop), which enables the G-switch circuitry to function (Figure 6), is installed by the airframe manufacturer between Pin 5 and Pin 12 on the D-SUB connector. If the ELT movement causes the G-switch acceleration threshold to be exceeded, the ELT will activate. When the D-SUB connector is removed, the ELT can be handled without the possibility of automatic activation.

Figure 6. Emergency locator transmitter installation wiring diagram (Source: ARTEX Products / ACR Electronics, Inc., *ARTEX ELT 1000 Emergency Locator Transmitter Description, Operation, Installation and Maintenance Manual*, Y1-03-0259 Rev. AA [15 January 2021], Figure 23: Typical 5-Wire Installations for Composite Airframes, p. 51, with TSB annotations)

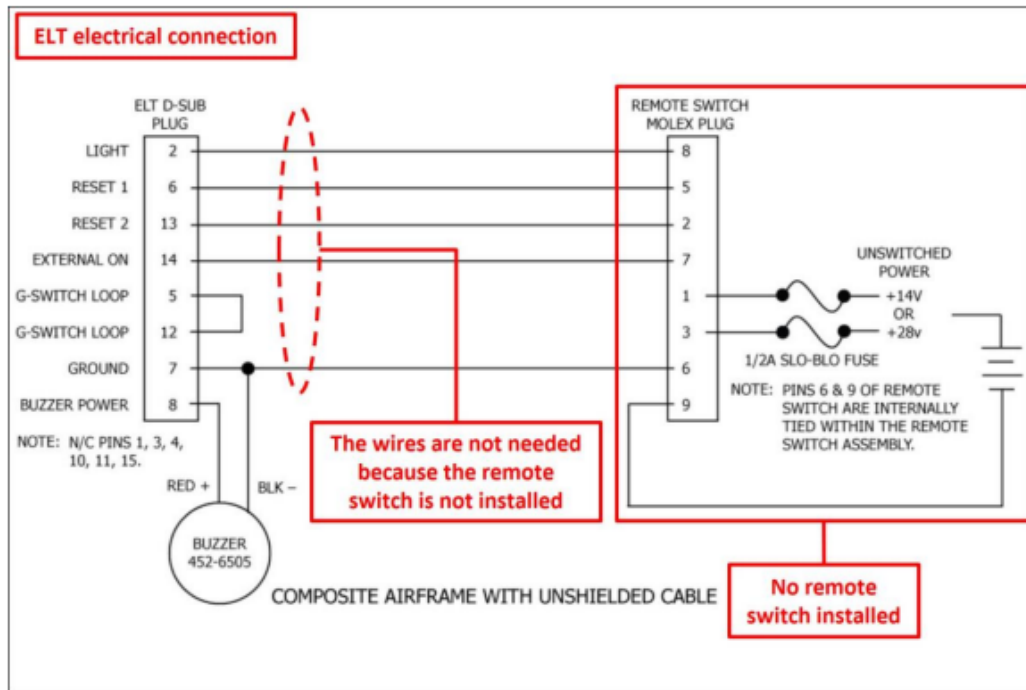

The ELT can also be manually activated by placing the ELT switch in the ON position. This forces the ELT to activate, regardless of whether the G-switch loop is in place.

Activation of the ELT is indicated by an audio tone transmitted on frequency 121.5 MHz, a sounding buzzer, and a flashing LED on the ELT. All of these indicators commence simultaneously with ELT activation.

To deactivate the ELT, the position of the ELT switch must be changed from ON to ARM. If activation is from the G-switch, the switch position must first be set to ON then changed to ARM.

A buzzer is required by Technical Standard Order⁸ to indicate ELT activation. The buzzer provides an audible alert in the aircraft cockpit when the ELT is active with a sound pressure level between 60 dB and 70 dB. The buzzer is powered by the ELT's battery pack and is not dependent upon an aircraft's power source for operation.

When the 406 MHz signal is detected by the Cospas-Sarsat satellite system, a position is calculated and the 121.5 MHz signal is used to home in on the accident site.

Location accuracy of the 406 MHz ELT is typically within 3 km. If position information from the aircraft navigation system is transmitted with the ELT signal, the accuracy improves to within approximately 100 m. Both the ELT and the aircraft navigation system on the occurrence aircraft were capable of the enhanced location accuracy. However, the aircraft navigation system was not connected to the ELT by the manufacturer and was not required to be during aircraft certification.

1.15.1.4 TSB examination and testing of the emergency locator transmitter

The ELT showed no signs of damage. Functional tests were performed at the TSB Engineering Laboratory in Ottawa, Ontario, to determine the serviceability of the ELT.

The battery pack was in a good state of charge. The antenna, coaxial cable, and buzzer were in good condition. The antenna and buzzer were securely affixed to the airframe metal bracket. The buzzer was tested using a power supply, and it functioned as intended.

The TSB followed the self-test procedure from the manufacturer's installation manual, and with the ELT D-SUB connector in place, the ELT emitted 6 pulses and the buzzer did not activate. The test result indicated an issue with the G-switch loop. This self-test procedure is required to be completed by the manufacturer during initial installation. However, the investigation was unable to determine whether the self-test had been completed, or, if it had, why the issue had not been identified.

The D-SUB 15-pin connector was dismantled, and examination of the connector revealed that the G-switch loop had not been installed by the aircraft manufacturer (Figure 7).

⁸ Federal Aviation Administration (FAA), Technical Standard Order TSO-C126b: 406 MHz Emergency Locator Transmitter (ELT) (effective 26 November 2012).

Figure 7. Disassembled emergency locator transmitter antenna and buzzer from the occurrence aircraft, with a close-up view of the female D-SUB connector showing the missing G-switch loop wire in inset (Source of main image and inset: TSB)

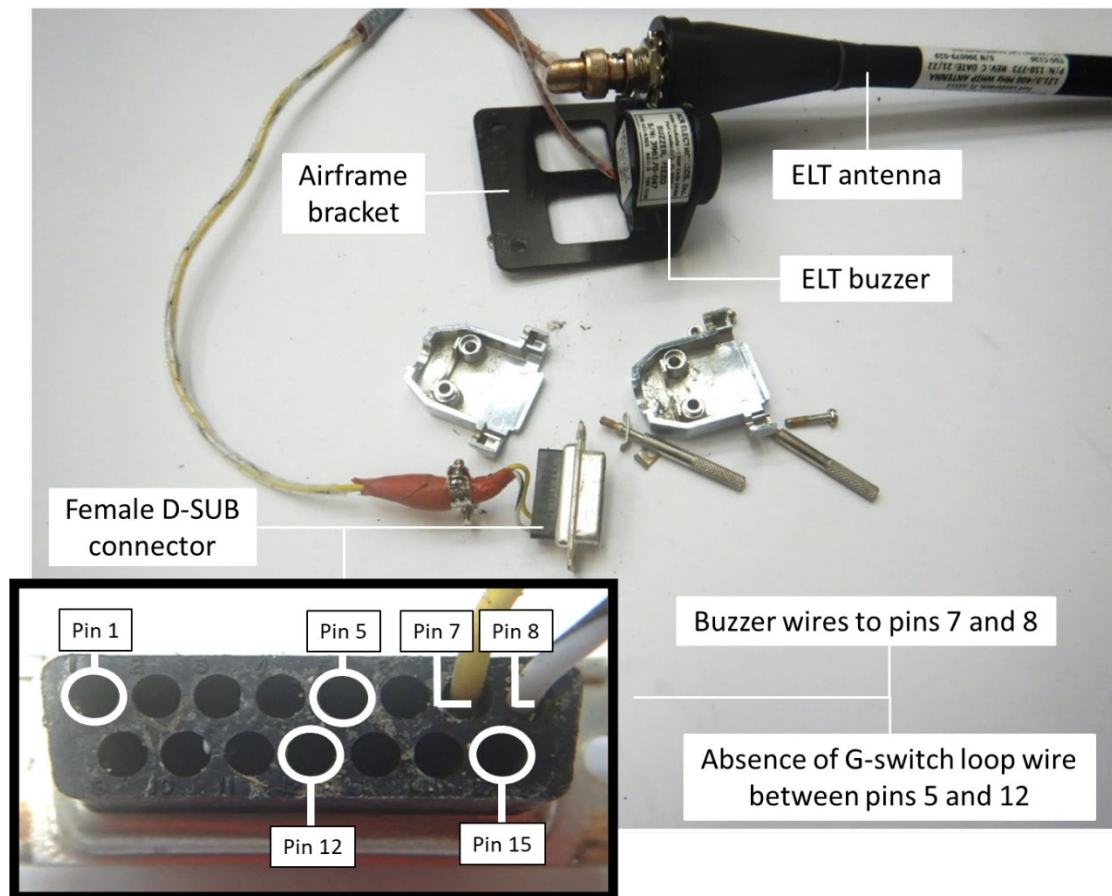

A laboratory-constructed G-switch loop was installed between Pin 5 and Pin 12 at the back of the D-SUB connector, and the self-test was re-initiated. The ELT emitted a 2-second-long pulse indicating that the system was “OK.” The buzzer did not activate.

Additionally, the investigation determined that the ELT’s buzzer wiring had been incorrectly installed. The buzzer wiring was reversed and not connected to the pins as shown in the installation drawings.

1.15.1.5 Emergency locator transmitter installation and maintenance

The investigation reviewed the maintenance records related to the installation and testing of the ELT. The aircraft was found to have been maintained in accordance with CLAA’s TC-approved maintenance schedule and with the Diamond DA20-C1 scheduled maintenance program, as described in the aircraft maintenance manual. The required scheduled inspections of the ELT outlined in the aircraft maintenance manual were performed. These inspections are periodic and consist of visual inspections only; no functional or performance testing of the ELT was conducted. As a result, CLAA had no opportunity to observe the ELT error code indicating that the G-switch loop was not installed.

Diamond's certification of the ELT installation in the occurrence aircraft, dated 16 February 2023, was the only instance recorded in the aircraft maintenance records where the ELT performance testing had been documented. The performance test described in *Canadian Aviation Regulations* (CARs) Standard 571 (Appendix G)⁹ was the only maintenance activity during the operational life of the aircraft where the ELT error code, indicating that the G-switch loop is not installed, could have been identified by maintenance personnel. The CARs Standard 571 (Appendix G) performance test and operational test are incorporated in the 12- and 24-month ELT testing requirements stated in CARs Standard 625 (Appendix C).¹⁰

Additionally, per CARs Standard 625 (Appendix C), the required 12-month operational test was not due until February 2024, and the required 24-month performance test was not due until February 2025.

1.15.2 Flight itinerary and flight plan

Section 602.73 of the CARs states that

[n]o pilot-in-command shall operate an aircraft in VFR [visual flight rules] flight unless a VFR flight plan or a VFR flight itinerary has been filed, except where the flight is conducted within 25 nautical miles of the departure aerodrome.¹¹

If an aircraft is overdue, search and rescue (SAR) action is only initiated at the specified SAR notification time. If a SAR time is not indicated, SAR action is initiated 60 minutes after the estimated time of arrival at the final destination indicated on a flight plan, or 24 hours after the estimated time of arrival indicated on a flight itinerary.

In general, pilots of CLAA flights operating in the local practice area use a VFR flight itinerary in lieu of filing a flight plan and use the responsible person¹² option in the regulations to activate a search. Following a flight, the pilot-in-command completes a flight log with the updated aircraft times, an action which then closes the flight itinerary.

The occurrence flight was dispatched using a VFR flight itinerary.

⁹ Transport Canada, SOR/96-433, *Canadian Aviation Regulations*, Standard 571: Maintenance, Appendix G – Maintenance of Emergency Locator Transmitters (ELTs), Section 4: Performance Test: ELTs capable of transmitting on the 406 and 121.5 MHz frequencies.

¹⁰ Ibid., Standard 625: Aircraft Equipment and Maintenance Standard, Appendix C – Out of Phase Tasks and Equipment Maintenance Requirements, Task 12. Emergency Locator Transmitters (ELTs), subparagraph (b)(i).

¹¹ Ibid., Subsection 602.73(2).

¹² A responsible person is "an individual who has agreed with the person who has filed a flight itinerary to ensure that the following are notified in the manner prescribed [...], if the aircraft is overdue, namely, (a) an air traffic control unit, a flight service station or a community aerodrome radio station, or (b) a Rescue Co-ordination Centre." (Source: Ibid., Section 602.70.)

1.16 Tests and research

1.16.1 TSB laboratory reports

The TSB completed the following laboratory reports in support of this investigation:

LP114/2023 – NVM Recovery – Various

LP144/2023 – ELT Analysis

1.17 Organizational and management information

1.17.1 Cooking Lake Aviation Academy Inc.

CLAA is a TC-authorized flight training unit that holds a valid flight training unit operator certificate issued under Subpart 406 of the CARs. It was founded in 1996 and is based at, and operates from, CEZ3. CLAA provides the training required to obtain Canadian pilot licences and ratings. At the time of the occurrence, in addition to 3 Diamond DA20-C1 aircraft, CLAA's training fleet consisted of a Cessna 172 and a Diamond DA42-TDI.

1.18 Additional information

1.18.1 Aerodynamic stall and incipient spin

A stall is a loss of lift and an increase in drag, which occurs when an aircraft is flying at an angle of attack greater than the angle that provides maximum lift. Regardless of airspeed, an aircraft always stalls when its wings reach this critical angle of attack.¹³ Stall speed varies depending on factors such as the aircraft's weight, power setting, flap position, centre of gravity, and angle of bank.

An incipient spin occurs when an aircraft stalls and one wing produces more lift than the other. Because the descending wing is at a greater angle of attack, it stalls even further and produces more drag, which triggers an autorotation. During this phase of the incipient spin, the flight path changes from horizontal to vertical.¹⁴ If the rotation continues, the aircraft could stabilize in a spin and follow a helical or corkscrew path downward (Figure 8). The spin characteristics of an aircraft can be affected by the aircraft's centre of gravity.¹⁵ A more rearward centre of gravity can result in a flatter spin attitude. The occurrence aircraft's centre of gravity was calculated to be toward the forward portion of the weight and balance envelope.

¹³ Transport Canada, TP 1102, *Flight Training Manual*, 4th Edition (revised 2004), p. 76.

¹⁴ *Ibid.*, p. 82.

¹⁵ National Aeronautics and Space Administration, James S. Bowman, Jr., *Summary of Spin Technology as Related to Light General-Aviation Airplanes*, NASA Technical Note D-6575, p. 15.

Figure 8. Illustration of an incipient spin (Source: TSB, based on Transport Canada, TP 1102, *Flight Training Manual*, 4th Edition [revised 2004], Figure 2-31)

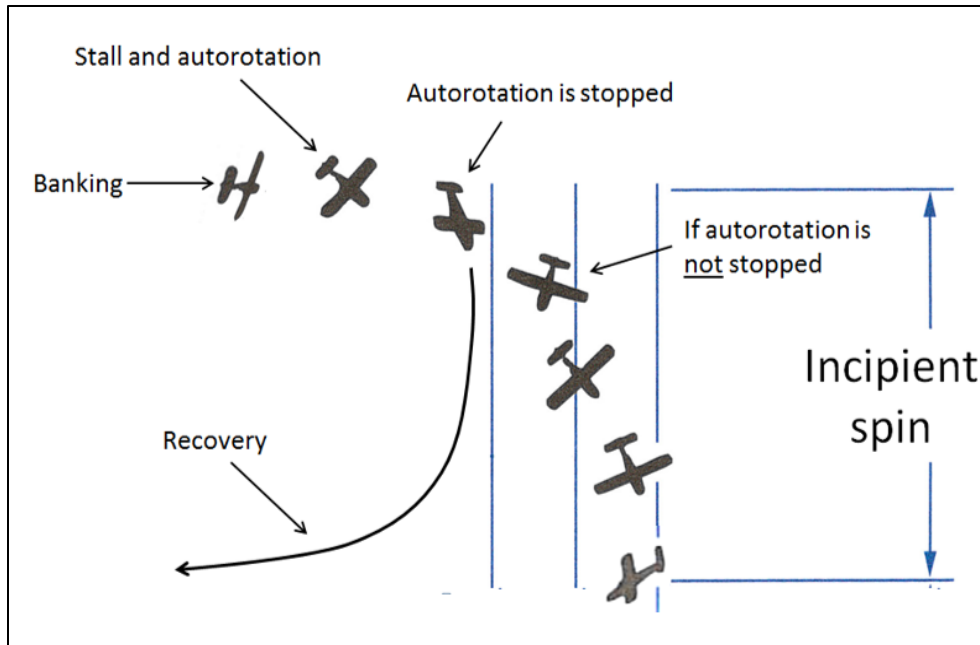

Generally, even if the pilot takes the necessary measures to stop the rotation as soon as it begins, the aircraft is in a vertical position while accelerating rapidly, and sufficient altitude is necessary to regain a horizontal flight path.

As a general estimate, most small aircraft can expect to lose about 500 feet of altitude per each 3-second turn while spinning. Greater altitude losses can be expected at higher density altitudes.^{16,17}

1.18.2 Spin certification of the Diamond DA20-C1

The Diamond DA20-C1 aircraft is certified in the utility category in accordance with Chapter 523 – VLA – Very Light Aeroplanes of the *Airworthiness Manual* and is approved to conduct all normal flight manoeuvres and utility category manoeuvres, including spinning (with wing flaps up).¹⁸

The *Diamond Aircraft DA20-C1 Flight Manual* contains a Caution statement that states, “[i]ntentional spinning is only permitted with flaps in cruise position.”¹⁹

¹⁶ Transport Canada, TP 13747, *Guidance Notes – Private and Commercial Pilot Training: Stall/Spin Awareness*, 2nd Edition (October 2003), p.10.

¹⁷ The investigation reviewed 18 videos of the DA20 series aircraft performing spins. The average altitude loss observed was: 840 feet for a ½-turn spin, 540 feet for a 1-turn spin, and 316 feet per turn for spins with more than 4 turns.

¹⁸ Diamond Aircraft Industries Inc., *Diamond Aircraft DA20-C1 Flight Manual*, Revision 29 (30 June 2021), Section 2: Operating Limitations, Subsection 2.9: Approved Maneuvers, p. 2-10.

¹⁹ Ibid., Section 4: Normal Operating Procedures, Subsection 4.4.16: Spinning, p. 4-27.

Additionally, with respect to spinning, subparagraph 523-VLA.221(c)(1) in the *Airworthiness Manual* states:

(1) The aeroplane shall recover from any point in a spin, in not more than one and one-half additional turns after normal recovery application of the controls. Prior to normal recovery application of the controls, the spin test shall proceed for six turns or 3 seconds, whichever takes longer, with flaps retracted [...].²⁰

1.18.3 Diamond DA20-C1 spin recovery procedure

The *Diamond Aircraft DA20-C1 Flight Manual* states the following spin recovery procedure:

3.3.6 Recovery from Unintentional Spin

- (a) Throttle.....IDLE
- (b) Rudderfully applied opposite to direction of spin
- (c) Control Stick.....ease forward
- (d) Rudderneutral, after rotation has stopped
- (e) Wing Flaps.....CRUISE
- (f) Elevator.....pull cautiously. Bring airplane from descent into level flight position. Do not exceed maximum permissible speed (V_{NE}).²¹

1.18.4 Spin recovery altitude

Guidance for spin recovery altitude is provided in TC's *Flight Training Manual* and *Flight Instructor Guide – Aeroplane*, which both state, under Exercise 13: Spinning, that “[a]ll practice spin recoveries should be completed no less than 2,000 feet above ground, or at a height recommended by the [m]anufacturer, whichever is the greater.”^{22,23}

The *Diamond DA20-C1 Aircraft Flight Manual* has no recommended altitudes for conducting spin training. Additionally, CLAA's flight operations manual does not contain any set policy for minimum spin entry altitudes; however, it was generally accepted by the CLAA flight instructors that spin entries would occur at 6000 feet ASL.

²⁰ Transport Canada, SOR/96-433, *Canadian Aviation Regulations, Airworthiness Manual*, Chapter 523: VLA – Very Light Aeroplanes, Subchapter B: [Flight], subparagraph 523-VLA.221(c)(1).

²¹ Diamond Aircraft Industries Inc., *Diamond Aircraft DA20-C1 Flight Manual*, Revision 29 (30 June 2021), Section 3: Emergency Procedures, Subsection 3.3.6: Recovery from Unintentional Spin, p. 3-18.

²² Transport Canada, TP 1102, *Flight Training Manual*, 4th Edition (revised 2004), Exercise Thirteen: Spinning, p. 83.

²³ Transport Canada, TP 975, *Flight Instructor Guide – Aeroplane* (revised September 2004), Part II: The Ground and Air Instruction Syllabus, Exercise 13: Spinning, p. 88.

1.18.5 Spin training

In the early 2000s, TC removed the requirement for a private pilot flight-test candidate to enter and recover from a spin. Although removed from the flight test, it is still part of the private pilot licence training, and TC has emphasized the importance of the recognition and prevention of stalls that can lead to a spin during this training. These concerns were communicated in guidance notes on stall/spin awareness in October 2003.²⁴

The flight instructor guidance in Exercise 13: Spinning in both the *Flight Training Manual* and the *Flight Instructor Guide – Aeroplane* explains that flight instructors should demonstrate recoveries at the initial sign of a spin, which is a wing drop during a stall. There is no recommendation or guidance on the number of turns in a spin a student pilot should experience. TC's *Flight Test Guide – Commercial Pilot Licence – Aeroplane* describes the spin exercise and states that the command from the examiner to recover will occur after one quarter turn of spin rotation.²⁵

The emphasis in the training is on recognition and immediate recovery—not on conducting multiple-turn spins. The guidance notes emphasize entering spins using real-world scenarios. They also state that during training, student pilots will enter and recover from a full spin on their own.²⁶

CLAA conducts spin training in accordance with the guidance material provided by the aircraft manufacturer and TC. A review of the training material used by the flight instructor indicated that, for the occurrence flight, spiral dives and spins were to be demonstrated by the flight instructor and practised by the student pilot.

A review of the student pilot's pilot training record (PTR) did not indicate that preparatory ground instruction, as required by the CARs,²⁷ for conducting spins and spiral dives had been provided before the occurrence flight. However, the previous lessons recorded in the PTR indicated that preparatory ground instruction had been conducted on the same day as the corresponding flight exercise and that the entry in the PTR was completed at the end of the flight. The investigation did not reveal any information regarding what had been covered in the pre-flight briefing²⁸ before the occurrence flight.

²⁴ Transport Canada, TP 13747, *Guidance Notes – Private and Commercial Pilot Training: Stall/Spin Awareness*, 2nd Edition (October 2003).

²⁵ Transport Canada, TP 13462, *Flight Test Guide – Commercial Pilot Licence – Aeroplane*, 6th Edition (January 2021), Flight Test Items, Ex. 13 Spinning.

²⁶ Transport Canada, TP 13747, *Guidance Notes – Private and Commercial Pilot Training: Stall/Spin Awareness*, 2nd Edition (October 2003), Spin Training, Introduction.

²⁷ Transport Canada, SOR/96-433, *Canadian Aviation Regulations*, 405.31(b).

²⁸ A pre-flight briefing is a "one-to-one practical briefing that is conducted just prior to a training flight for the purpose of ensuring that the trainee understands exactly what will take place during the flight." (Source: *Ibid.*, Subsection 400.01(1).)

The flight instructor's ground-instruction lesson plan did indicate that recoveries should be made by at least 2000 feet AGL. The flight instructor did not have any lesson plans for the in-flight portion of the training.

1.18.6 Instructional method

There are instructional methods used by flight instructors when conducting ground school training, pre-flight and post-flight briefings, and the air exercises. One of the methods described in the TC *Flight Instructor Guide – Aeroplane*²⁹ is the Demonstration-Performance method of teaching. According to the guide, this method can be broken down into 5 basic stages:

1. Explanation
2. Demonstration
3. Student pilot performance
4. Instructor supervision
5. Evaluation³⁰

The explanation and demonstration stages may be performed at the same time, or completed separately. This is where the flight instructor could demonstrate a flight exercise and simultaneously give an explanation of what is being done and why, or the flight instructor could give an explanation of what is intended to be done and then perform the exercise. Different instructors will approach the training differently.

The *Flight Instructor Guide – Aeroplane* goes on to explain the next 2 stages:

Student performance and instructor supervision are always carried out concurrently during the initial stages of training. A student should not be allowed to make a major error at this time. [The flight instructor's] supervision must be close enough to detect the start of an error and [the instructor] must correct the student at that point. [...] The student should be allowed to perform the task in small segments with [the instructor] providing close supervision of each segment.³¹

On subsequent attempts, depending on how successful the 1st attempt was, the flight instructor can add more tasks for the student pilot to carry out. This process is continued until the flight instructor feels the student pilot can complete the manoeuvre alone. At that point, the student pilot performance and instructor supervision stages are complete, and the flight instructor can proceed to the evaluation.

At the evaluation stage of the Demonstration-Performance method, student pilots have an opportunity to show that they can perform the manoeuvre without assistance. While the

²⁹ Transport Canada, TP 975, *Flight Instructor Guide – Aeroplane*, (revised September 2004), Part I: Learning and Learning Factors, The Demonstration-Performance Method of Teaching, pp. 20–22.

³⁰ *Ibid.*, p. 20.

³¹ *Ibid.*, p. 21.

student pilot is performing the manoeuvre, the flight instructor must remain silent and avoid offering any kind of assistance. The flight instructor

[...] must, however, observe the entire manoeuvre very carefully, so that [the instructor] can analyze any errors that the student may make and de-brief accordingly. [...] Success or failure during the evaluation stage of the lesson will determine whether [the instructor will] carry on with the next exercise or repeat the lesson.³²

³² Ibid., pp. 21–22.

2.0 ANALYSIS

The investigation did not identify any issues related to the airframe or engine that could have prevented a recovery from the spin.

Because flight data were limited and no cockpit voice recorder was available to the investigation, it was not possible to determine the actions of the flight instructor and student pilot, and a precise reason why the 2nd spin recovery was unsuccessful.

The analysis will focus on the spin training conducted during the occurrence flight and the performance of the emergency locator transmitter (ELT).

2.1 Spin

The aircraft entered deliberate spins twice, which is consistent with the planned training exercise of the occurrence flight.

Although not documented in Cooking Lake Aviation Academy Inc. manuals, the normal practice for the flight training unit was to conduct spin entries at 6000 feet above sea level (ASL), or about 4000 feet above ground level (AGL). Entry at this altitude allows ample altitude for a 1-turn spin and a recovery by a height of 2000 feet AGL in the local flying area.

The 1st spin, which was likely demonstrated by the flight instructor, started at 5725 feet ASL (3531 feet AGL) and recovered at 4150 feet ASL (1956 feet AGL). This would be consistent with a 2-turn spin given that the Diamond Aircraft Industries Inc. DA20-C1 loses about 500 to 800 feet per turn.

The 2nd spin entry was initiated at 4725 feet ASL (2531 feet AGL). While a spin from this height should have been recoverable, neither the student pilot nor the flight instructor was able to effect a recovery. The investigation was unable to determine the reason.

The successful recovery from the 1st spin indicates that the flight instructor was capable of conducting an effective spin recovery. This recovery and the post-accident medical exam suggest that there were no pre-existing physiological or medical conditions that would have prevented a recovery from the 2nd spin.

Finding as to causes and contributing factors

During spin training, the aircraft entered a spin and, for reasons unknown, the flight instructor and student pilot were unable to accomplish the recovery, and the aircraft collided with the surface of Beaverhill Lake, Alberta.

Student pilots are not expected to perform flight exercises perfectly in their first few attempts. In manoeuvres involving larger altitude losses, such as practice spins, ensuring that a liberal amount of height is available for practice is essential. Planning to recover from spin manoeuvres at heights lower than those recommended leaves less time to recover from less than ideal flight control inputs that student pilots may make while learning the techniques for spin entry and recovery.

Considering that the 1st spin recovery required 1575 feet, entering the 2nd spin at 2531 feet AGL may not have afforded enough room for recovery before the recommended height of 2000 feet AGL.

Finding as to risk

If spin training is initiated from a height that does not provide a pilot a wide enough recovery margin, there is an increased risk of collision with terrain.

2.2 **Emergency locator transmitter**

The ELT on board the occurrence aircraft was serviceable at the time of the occurrence except for the automatic activation function through the G-switch. The ELT did not activate upon impact because the G-switch loop wire was not found installed during a post-occurrence inspection. Consequently, the automatic activation of the ELT through the G-switch was inhibited. It is presumed that the G-switch loop had not been installed by the aircraft manufacturer during aircraft assembly.

As a result, search and rescue crews did not have a precise location for the accident site or a signal that could be homed in on using equipment onboard their aircraft. It was therefore necessary to commence the search in a geographic area much larger than otherwise would have been required, increasing the time it took to locate the aircraft.

The post-occurrence laboratory examination determined that the wire connections for the buzzer were not installed per the manufacturer's installation wiring diagram. As a result, the buzzer was prevented from operating during testing.

The self-test, as described and carried out in accordance with the ARTEX ELT 1000 installation manual, would have likely detected the absence of the G-switch loop between Pin 5 and Pin 12 and the nonfunctional state of the buzzer when the ELT was tested and inspected by Diamond Aircraft Industries Inc. in accordance with *Canadian Aviation Regulations* Standard 571 (Appendix G) on 16 February 2023.

In this occurrence, the ELT was installed without the G-switch loop, which prevented automatic activation. Consequently, search and rescue efforts to reach the accident site were delayed.

Finding as to risk

If ELTs are incorrectly installed and/or tested, they may not function as designed, increasing the risk that search and rescue efforts are not timely.

3.0 FINDINGS

3.1 Findings as to causes and contributing factors

These are conditions, acts or safety deficiencies that were found to have caused or contributed to this occurrence.

1. During spin training, the aircraft entered a spin and, for reasons unknown, the flight instructor and student pilot were unable to accomplish a recovery, and the aircraft collided with the surface of Beaverhill Lake, Alberta.

3.2 Findings as to risk

These are conditions, unsafe acts or safety deficiencies that were found not to be a factor in this occurrence but could have adverse consequences in future occurrences.

1. If spin training is initiated from a height that does not provide a pilot a wide enough recovery margin, there is an increased risk of collision with terrain.
2. If emergency locator transmitters are incorrectly installed and/or tested, they may not function as designed, increasing the risk that search and rescue efforts are not timely.

4.0 SAFETY ACTION

4.1 Safety action taken

4.1.1 Diamond Aircraft Industries Inc.

On 24 November 2023, Diamond Aircraft Industries Inc. issued a mandatory service bulletin (MSB), DAC1-25-05, to highlight safety issues with the DA20-C1 series aircraft and, specifically, the installation of the ARTEX ELT 1000 emergency locator transmitter (ELT) system in its aircraft.

The MSB calls for the inspection of the ELT connector wiring and, if necessary, the corrective actions needed to ensure full functionality of the ELT in the event of an accident.

In addition to issuing the MSB, Diamond Aircraft Industries Inc. conducted a factory campaign to ensure compliance among all affected aircraft and also updated the aircraft production drawings.

4.1.2 Cooking Lake Aviation Academy Inc.

The Cooking Lake Aviation Academy Inc. revised its flight operations manual, integrating the emergency response procedures and formalizing minimum altitudes for upper-air work and spins. The new flight operations manual was approved by Transport Canada (TC) and disseminated to staff on 12 April 2024.

4.1.3 Transport Canada

TC conducted a scheduled Class 1 flight instructor rating renewal flight test on the flight training unit's Chief Flight Instructor on 15 September 2023. The TC Inspector who conducted the flight test focused on the spin exercise as part of the ground and in-flight components of the flight test.

This report concludes the Transportation Safety Board of Canada's investigation into this occurrence. The Board authorized the release of this report on 18 December 2024. It was officially released on 29 January 2025.

Visit the Transportation Safety Board of Canada's website (www.tsb.gc.ca) for information about the TSB and its products and services. You will also find the Watchlist, which identifies the key safety issues that need to be addressed to make Canada's transportation system even safer. In each case, the TSB has found that actions taken to date are inadequate, and that industry and regulators need to take additional concrete measures to eliminate the risks.